

Microphone Boom & Turntable

Nor265

- **Building Acoustic measurement in accordance with ISO 140**
- **Reverberation Time measurements in accordance with ISO 354**
- **Sound Power measurements in accordance with ISO 3740 series**
- **Directional response measurements of loudspeakers and microphones**

Features:

- Sweep of $\pm 90^\circ$ and $\pm 180^\circ$
- User defined sweeps
- Selectable sweep times
- PC-control via RS-232 interface
- User-defined fixed boom-positions
- Accurate positioning of turntable angle
- Low-noise design
- No noisy slip-rings



Introduction

The Microphone Boom/Turntable type Nor265 may be used as a stand-alone device to obtain the spatial average of sound level by moving the measurement microphone back and forth continuously.

Alternatively, it may be used to place the microphone in various fixed positions.

Main applications are building acoustic measurements (ISO 140-series), measurement of sound absorption in a reverberation room (ISO 354) and determination of sound power levels of noise sources using sound pressure (ISO 3741).

The sound emission from the unit is very low, especially when operated at low speeds. Due to the oscillating back and forth movement, the normal microphone cable may be led through the hollow main shaft without the need for any noisy slip rings.

The unit may be equipped with a turntable plate or chuck for mounting of different test objects. Main application is measurement of directional responses of acoustic transducers such as microphones or loudspeakers.

The unit is robust and constructed for years of maintenance-free operation.

Microphone Boom

A number of applications require measurement of the spatial average of the sound pressure level in a room. The average level may be obtained by measuring the level in different position and then calculation the average level:

$$\tilde{L} = \frac{1}{N} \sum_{i=1}^N 10^{L_i/10}$$

Nor265 may be used for moving the microphone from position to position or the average may be obtained by moving the microphone continuously while measuring the average sound level.

Normally the energetic average is required. This may be obtained direct-



ly by use of an integrating sound level meter set to indicate the timeaverage sound level Leq.

Nor265 is normally set up to produce an oscillating angular movement backwards and forwards. The time for a complete period may be specified. The integration time for the measurement is normally set to one or a whole number of oscillations.

Operation

When delivered, the rotary switch for manual operation is programmed to sweeps of ±90° and ±180°, respectively.

The default set is for the following actions:

- Sweep ± 180°, sweep time 120 sec
- Sweep ± 180°, sweep time 60 sec
- Sweep ± 180°, sweep time 30 sec
- Sweep ± 90°, sweep time 15 sec
- Sweep ± 90°, sweep time 30 sec
- Sweep ± 90°, sweep time 60 sec

If Nor265 is equipped for remote operation (option 3), the operation of the sweep selection switch may be reprogrammed to obtain other sweeps or to obtain specified positions. The reprogramming of the user interface is most easily performed with the Windows program Nor1028 accompanying the remote operation option.

Up to eight positions may be selected by the switch on the front. The positions may be programmed by use of the serial interface and will be stored in the internal memory of the device.

Alternatively, the switch may be programmed to contain a start angle and a fixed step angle.

Turntable

Nor265 may be used to turn a device continuously around or to move it to a specified angle. The speed and acceleration for a movement may be specified accurately and within a wide range.

Main application is measurement of directional response of an acoustic transducer. The turning moment is limited in order to avoid safety problems but the Nor265 may still carry significant loads. The position and the speed are computer controlled and ensure a smooth and safe movement from one position to another. Remote commands facilitate computer control and fully automatic measurements.

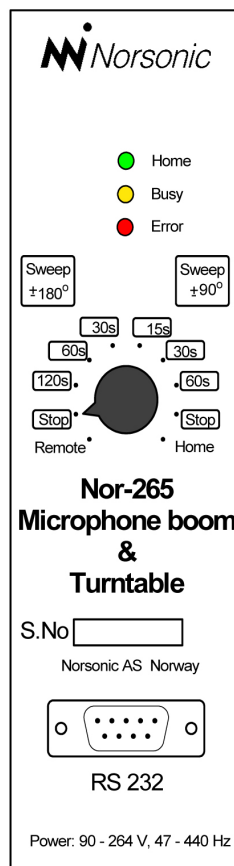

Nor265 may be mounted in any position, even upside down. The main shaft is hollow and allows the passage of signal cables.

Reference angle

When Nor265 is switched on, the actual angular position will be the reference 0°, and the sweep is referred to this start angle. Thus the sweep will be ± 90° from this start angle, or ± 180° dependent on the sweep selected.

However, if the switch is set to “Go home” before any sweep is selected, the referred 0° will be a fixed position referred to the body of Nor265.

Technical Design

Nor265 uses a digital signal processor (DSP) to obtain accurate positioning along with a simple and robust mechanical design. Accuracy in speed and acceleration are ensured by the precision of a crystal clock. The design allows a unique combination of specifications suitable for microphone boom applications as well as a general turntable.

The figure shows a block-diagram of the Microphone Boom/Turntable Nor265. The motor is a stepper motor designed for continuous move-

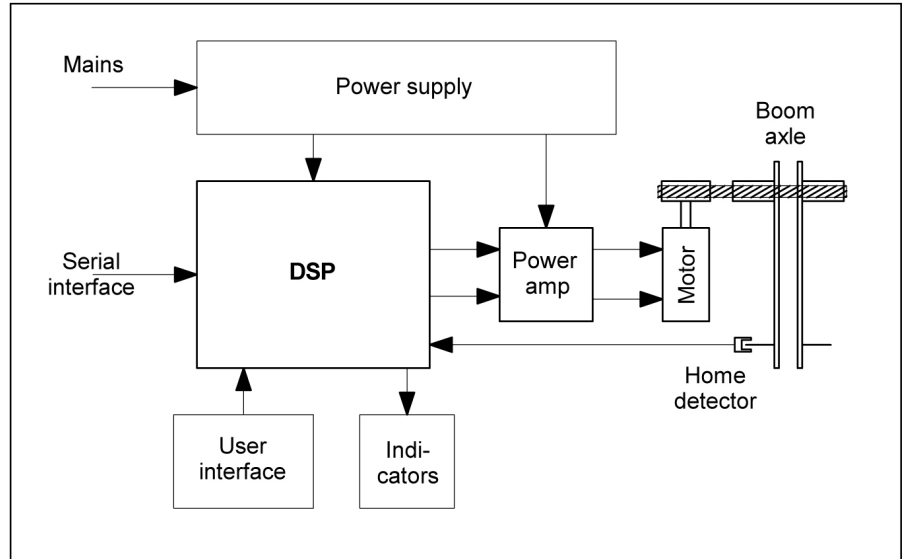

ment (micro-stepping). A digital signal processor controls the position of the motor shaft directly with a very high resolution. Since the systems apply no feedback, it will never generate the type of noise often found in feedback system due to play as the system wears.

The motor is powered all the time, even at rest, and will therefore need no braking action.

The benefits of the design include simple and robust mechanical parts. No gear box, only a timing belt is needed between the motor and the main shaft. The stepper motor is robust without any commutator or brushes.

Blocking the movement will not harm the motor. The table may be turned by hand, even when powered, to obtain a suitable reference angle. Due to the design, the torque will partly depend on the actual angle for the motor.

This modulation of the torque may under certain circumstances create small vibrations that may be enhanced by a resonance in the device placed on the table.

The torque of the device is limited in order not to harm the user or devices placed on or around the turntable.

Still it can carry considerable loads in any direction. Note therefore that the loads have to be balanced around the turning axis.

Nor1029 Control Software

If Nor265 is installed with Option 3 for remote operation, it may be controlled by the accompanying Windows program Nor1029.

When you start the program, Nor1029 set up the Nor265 with the default settings from the virtual panel of the program. The user may then change the settings as desired from the PC.

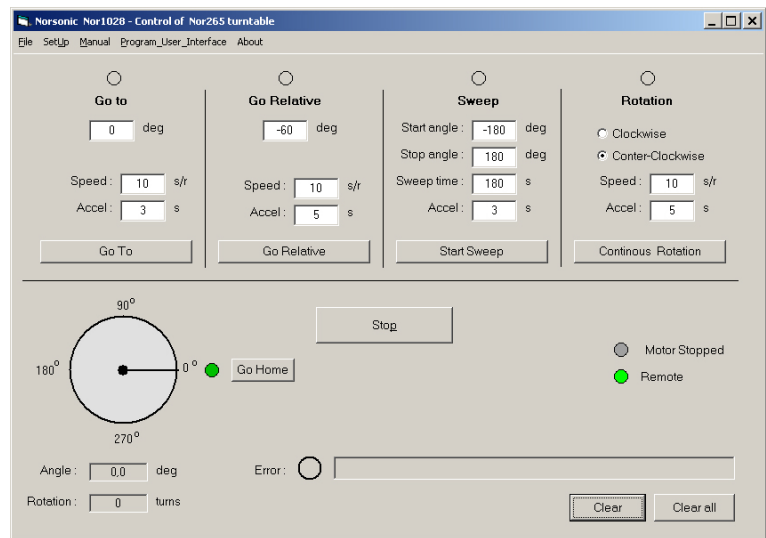

Virtual control panel



Specifications

Max sound level (re. 20 µPa)	Diameter 202mm, Height: 171 mm
Size – main body:	6 kg
Mounting:	Tripod allows inclined traverse plane Diameter of tripod mounting stud: 3/8"
Main axle dimension:	Outer diameter: 30 mm, Inner diameter: > 22 mm
Units to be mounted on turn axle:	Microphone boom (option 1) Turn table (d=300 mm) (option 2) Chuck (2 – 13 mm) (option 2)
Boom radius	0,8 – 2 m (continuously adjustable)
Rotation angle:	-241592002° to +241592002° (more than 600.000 revolutions) May also be set to rotate continuously at a specified direction and speed
Resolution:	0.01°
Angle accuracy (no torque):	< 0.8°. Typical. < 0.05° if moved in one direction
Max load (any direction):	500 N
Max torque loading:	2 Nm
Typical error from loading torque:	0.3 deg/Nm
Power supply:	90 – 264V AC / 47 – 440 Hz
Fuses:	2,5 A slow blow (IEC 60127)
Remote operation (option 3):	RS-232 interface: 9600 – 115200 baud
Noise emission:	< 10 dBA at rest < 23 dBA for all default rotations and sweep times (i.e. >20 sec/rev) The noise is measured in an anechoic chamber with the moving microphone placed 1,5 m from the main body
Temperature range	-10 to 50 °C
Humidity:	0 – 90 %RH

Ordering information

Nor265	Main Motor Unit including mains cable. Option 1 or Option 2 must be ordered simultaneously
Nor265/Option 1	Microphone Boom Accessories including adjustable rod, counterweight, 1/2" preamplifier holder, tripod, tripod-adaptor
Nor265/Option 2	Turntable Accessories including table-plate, chuck, mounting adapter
Nor265/Option 3	RS-232 serial interface including 2m cable and Nor1029 Control Software (Please note that option 3 must be ordered together with the Main Motor Unit as this option is installed at the factory)